

**KNIGHT**

**PROVEN INNOVATORS**  
of Material Handling Systems

# Manipulators

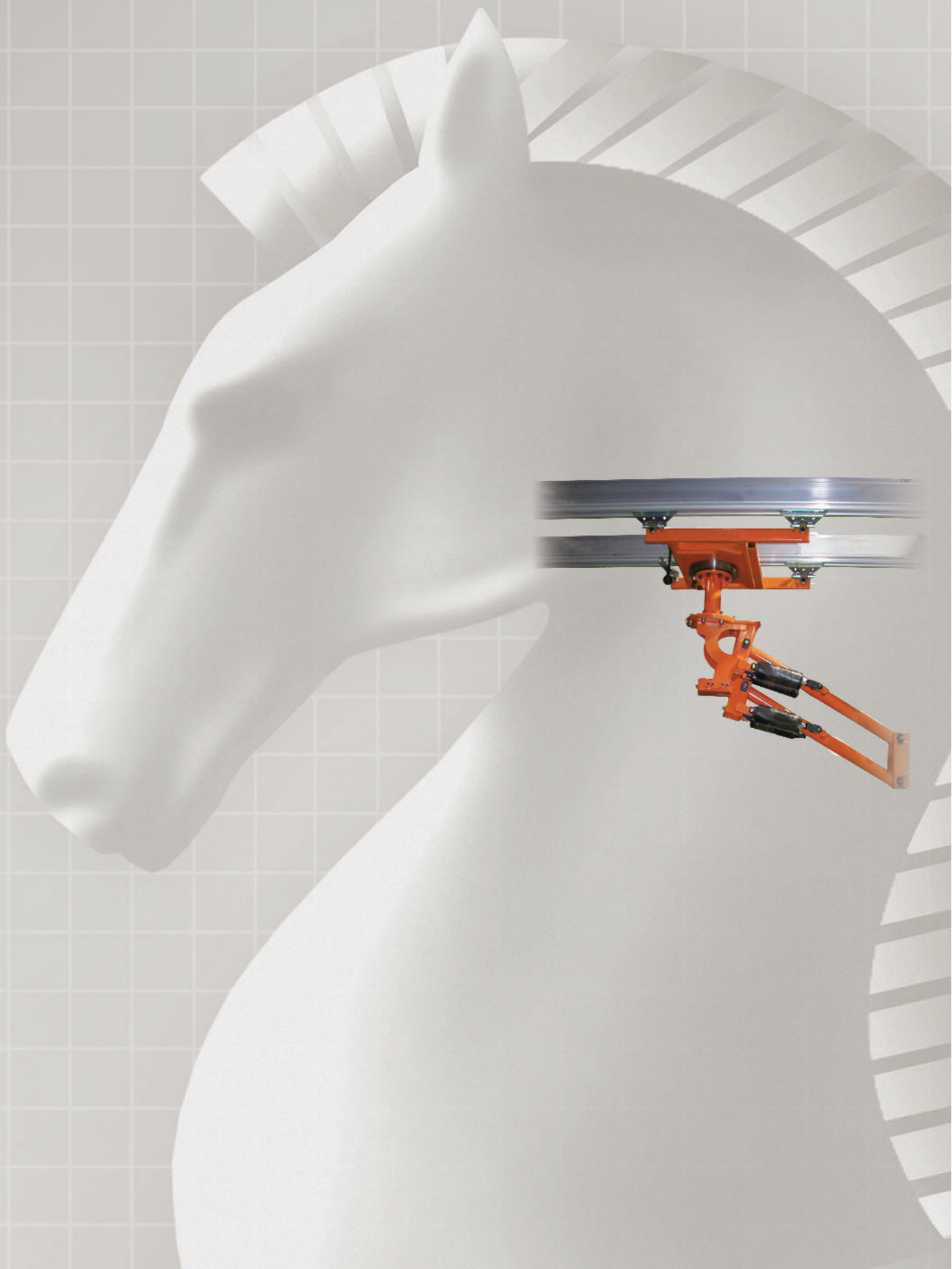

## Light Duty Arm

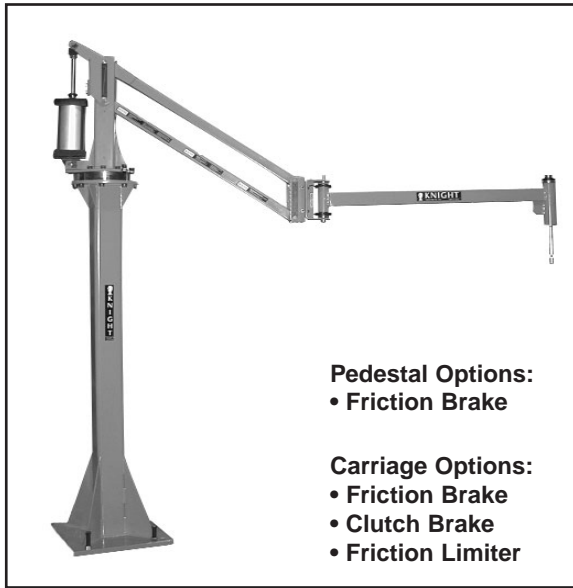

**Pedestal Options:**

- Friction Brake

**Carriage Options:**

- Friction Brake
- Clutch Brake
- Friction Limiter

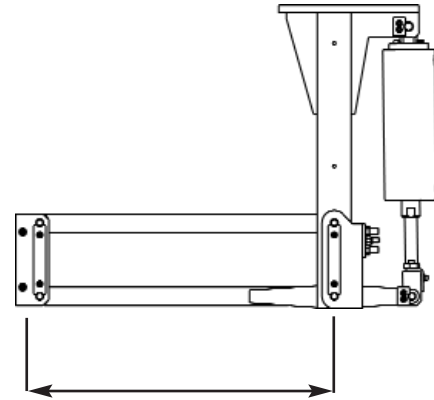

Available in 6 in [15.24 cm] increments  
24 in [61 cm] - 48 in [121.9 cm] standard

Model	Description	Maximum Reach ft [m]	Capacity lbs [kg]
AOA5000	Light Duty Articulating Arm	4 [1.2]	75* [34]

\* Arm capacity varies with reach.  
Capacity rated at 100 psi air supply.

## Medium Duty Arm

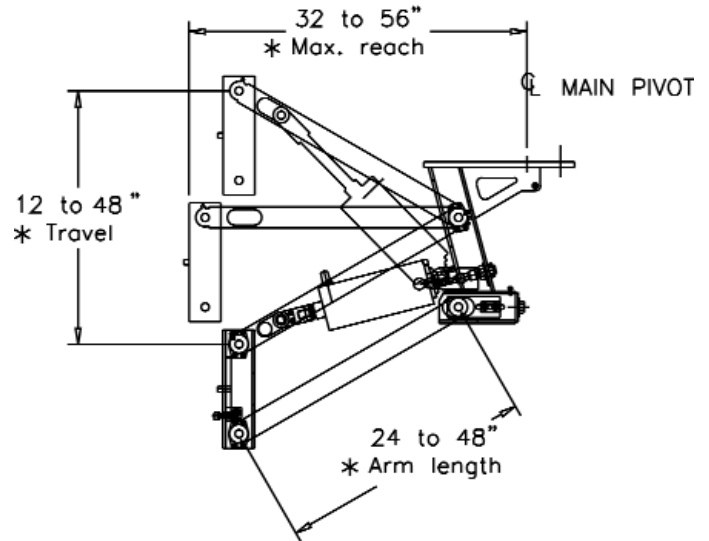
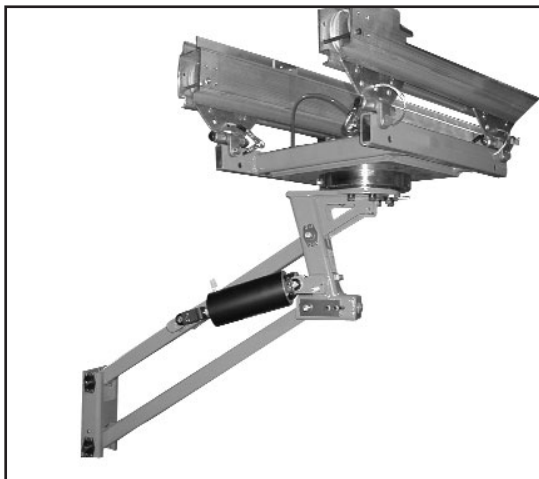

Available in 6 in [15.24 cm] increments  
24 in [61 cm] - 48 in [122 cm] standard

Travel ft [m]	Reach ft [m]	Arm Length ft [m]
1 [.305]	2.67 [.814]	2 [.609]
1.5 [.457]	3.67 [1.12]	3 [.914]
2 [.609]	2.67 [.814]	2 [.609]
2.5 [.762]	3.17 [.966]	2.5 [.762]
3 [.914]	3.67 [1.12]	3 [.914]
3.5 [1.07]	4.17 [1.27]	3.5 [1.07]
4 [1.22]	4.67 [1.42]	4 [1.22]

**Pedestal Options:**

- Friction Brake

**Carriage Options:**

- Friction Brake
- Clutch Brake
- Friction Limiter

Model	Description	Capacity lbs [kg]
AAA6000	Medium Duty Articulating Arm	350* [159]

\* Arm capacity varies with reach.  
Capacity rated at 100 psi air supply.

## Heavy Duty Arm

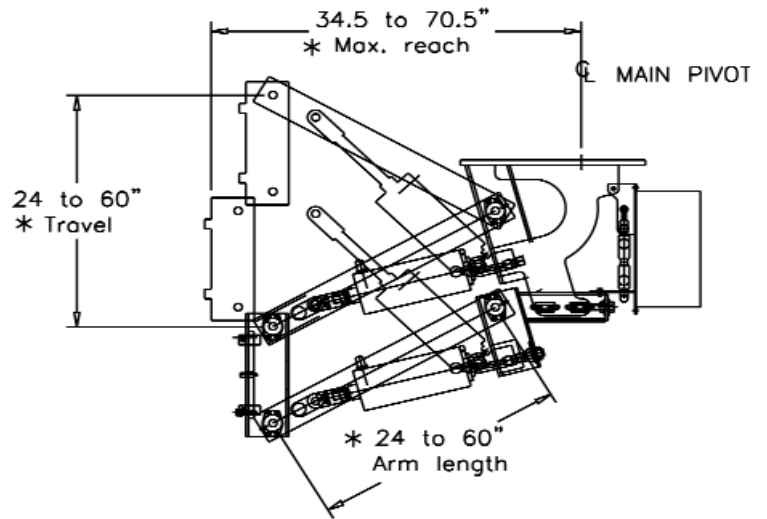

Travel ft [m]	Reach ft [m]	Arm Length ft [m]
2 [.609]	2.88 [.873]	2 [.609]
2.5 [.762]	3.38 [1.03]	2.5 [.762]
3 [.914]	3.86 [1.18]	3 [.914]
3.5 [1.07]	4.38 [1.33]	3.5 [1.07]
4 [1.22]	4.88 [1.48]	4 [1.22]
4.5 [1.37]	5.36 [1.63]	4.5 [1.37]
5 [1.52]	5.88 [1.79]	5 [1.52]

### Pedestal Options:

- Friction Brake

### Carriage Options:

- Friction Brake
- Clutch Brake
- Friction Limiter

\* Available in 6" increments

Available in 6 in [15.24 cm] increments  
24 in [61 cm] - 60 in [152 cm] standard

Model	Description	Capacity lbs [kg]
AAA7000	Heavy Duty Articulating Arm	800* [363]

\* Arm capacity varies with reach.  
Capacity rated at 100 psi air supply.

## Path Guided Arm

***Knight Path Guided Arm*** guides the fixture through a predefined path. Ideal when part alignment is crucial. Available options include a clutch assembly that locks rotation on arm while not in use or as required during operation.

Cam and roller control vertical travel of articulating arm.

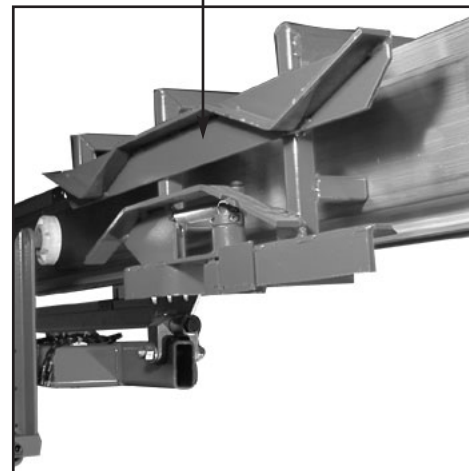

## Vertical Arm

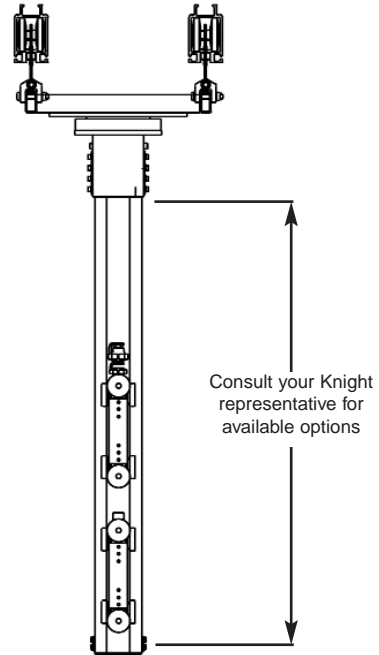
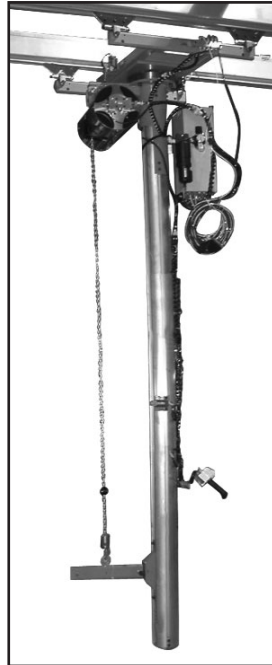

Model	Description	Capacity lbs [kg]	Minimum Travel in [cm]
VBA2000	Heavy Duty Vertical Balancer Arm	350 [159]	20 [50.8]
VBA3000	Extra Heavy Duty Vertical Balancer Arm	500 [227]	20 [50.8]

Capacity rated at 100 psi air supply

### Available Options:

- Friction Brake
- Clutch Brake
- Friction Limiter

## Carriage Arm

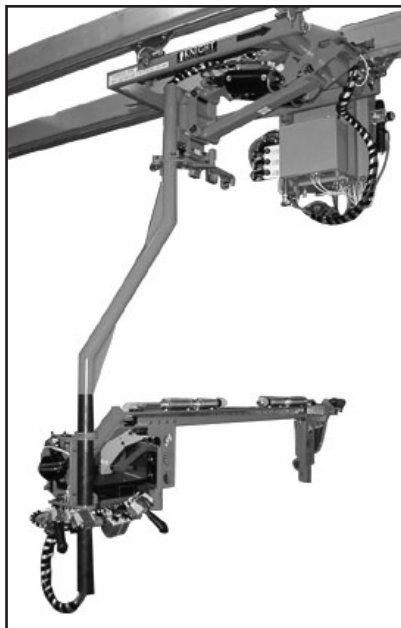

Model	Description	Maximum Reach ft [m]	Capacity lbs [kg]	Vertical Travel ft [m]
CAA1000	Carriage Arm	4 [1.2]	500 [227]	2 [.61]

Capacity rated at 100 psi air supply

***Knight Carriage Arm*** places the body of the arm between the runway saving up to 36 in [91cm] of head room. Ideal for heavy offset loads in parallel with the running rails.

## Banjo Arms

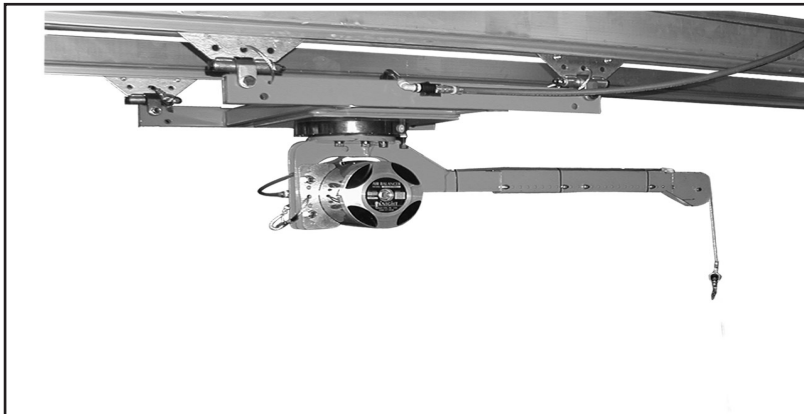

**Banjo Arms** offer versatility by enabling the operator to extend beyond the working limits of a rail system. A Knight balancer mounted on the banjo arm lifts and lowers the load.

Model	Description	Capacity lbs [kg]	Reach in [cm]
JDA1000028	Dual Bridge Banjo Arm	100 [45]	48 to 60 [122 to 152]
JDA1000076	Dual Bridge Banjo Arm	150 [68]	48 to 60 [122 to 152]
JDA2000073	Dual Bridge Banjo Arm	225 [102]	48 to 60 [122 to 152]
JDA3000073	Dual Bridge Banjo Arm	350 [158]	48 to 60 [122 to 152]
JDA3000117	Dual Bridge Banjo Arm	225 [102]	48 to 60 [122 to 152]
JDA5000080	Dual Bridge Banjo Arm	500 [226]	48 to 60 [122 to 152]

**Dual Bridge Options:**

- Friction Brake
- Clutch Brake

Capacity rated at 100 psi air supply

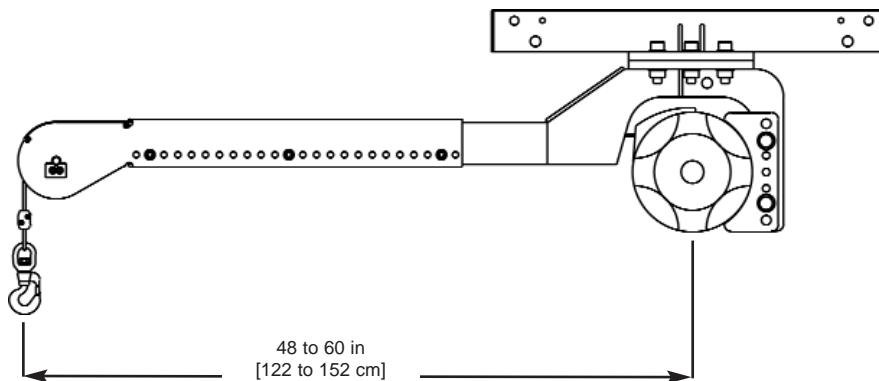

Adjustable in 1 in [2.5 cm] increments

Model	Description	Capacity lbs [kg]	Reach in [cm]
JSA1000076	Single Bridge Banjo Arm	150 [68]	48 to 60 [122 to 152]
JSA2000073	Single Bridge Banjo Arm	225 [102]	48 to 60 [122 to 152]
JSA3000073	Single Bridge Banjo Arm	350 [158]	48 to 60 [122 to 152]
JSA3000117	Single Bridge Banjo Arm	225 [102]	48 to 60 [122 to 152]

**Single Bridge Options:**

- Friction Brake
- Clutch Brake
- Friction Limiter

Capacity rated at 100 psi air supply

## Torque Pak

***Knight Industries Torque Pak*** is designed to absorb torque reaction from fastening devices and balance the tool. Torque paks include a standard fixed tool holder. Custom designed tool holders are available upon request. Please contact your Knight representative for details.

- Handles up to 200 ft/lbs [271 Nm] of torque
- Ten year warranty on parts and labor\*
- Lengths are adjustable in plant
- Rigid design improves tool accuracy
- Custom travel and heights available
- Can be designed for higher torque capacities

\*Warranty includes Knight mechanical components only. Excludes cylinder and regulator covered by manufacturers warranty. Labor is warranted on torque paks returned to Knight Industries to be rebuilt. Customer shall pay all shipping.

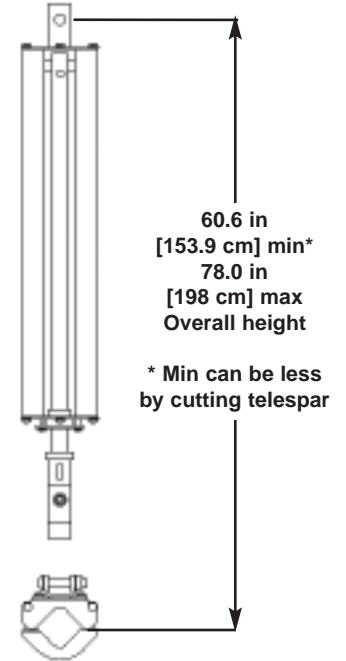

Model	Description	Balance Capacity lbs [kg]	Vertical Travel in [cm]	Collapsed Height in [cm]	Maximum Torque ft/lbs [Nm]
ATA2500	Torque Arm	60 [27]	19.4 [49.3]	40 [101]	200 [271]

Capacity rated at 100 psi air supply.

## Mini Arm

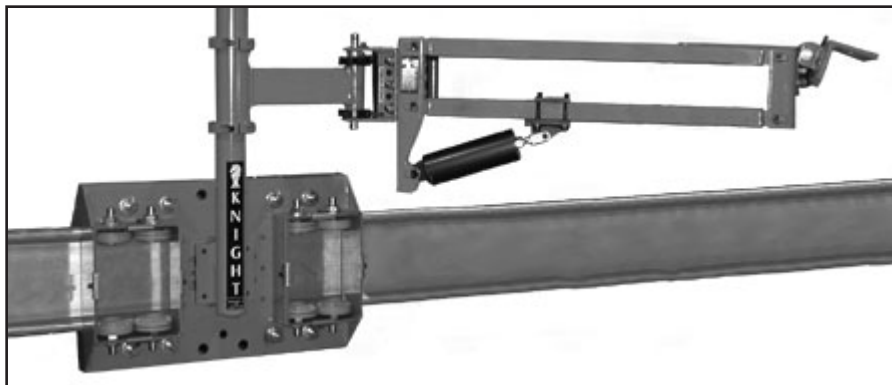

***Mini Arms*** are pivot mounted which is optimal for small tools. Includes a standard tool holder ASA9500.

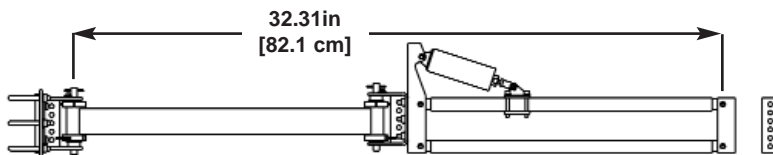

Travel 11.5 in [29.2 cm]

Model	Description	Capacity lbs [kg]	Maximum Reach ft [m]	Travel in [cm]
AMA3000	Mini Arm (Dual)	27 [12]	7 [2]	28 - 38 [71 - 97]
AMA4000	Mini Arm (Single)	27 [12]	7 [2]	28.8 - 32.9 [73 - 83.6]

Capacity rated at 100 psi air supply.

**Available Options:**  
• Tool Holders

## Bench Mounted Arm

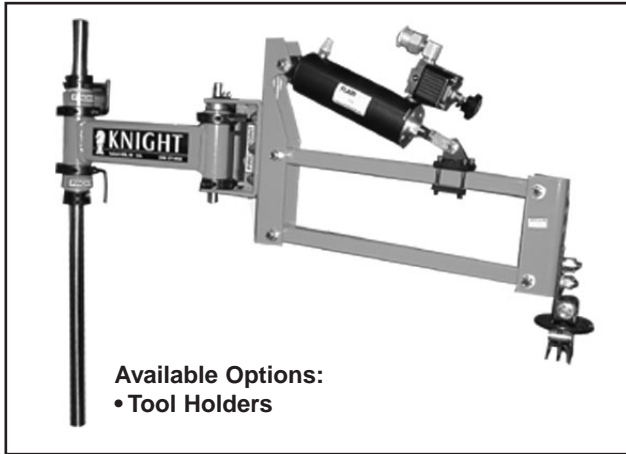

Available Options:  
• Tool Holders

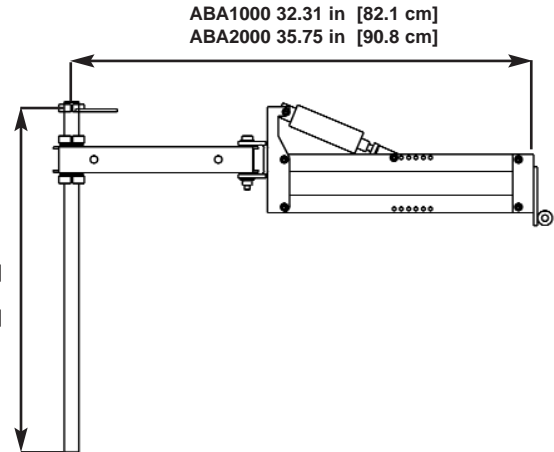

Model	Description	Balance Capacity lbs [kg]	Travel in [cm]
ABA1000-1	Top Mounted Light Duty Bench Arm	15 [7.0]	11.5 [29.2]
ABA1000-2	Side Mounted Light Duty Bench Arm	15 [7.0]	
ABA2000-1	Top Medium Duty Bench Mounted Arm	25 [11.0]	13.0 [33.0]
ABA2000-2	Side Medium Duty Bench Mounted Arm	25 [11.0]	

Capacity rated at 100 psi air supply.

***Bench Arms*** work well on small parts assembly applications. Includes a standard tool holder ASA9500.

## Tool Holders

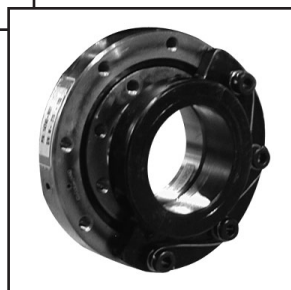

Model	Description	Fits Tool Sizes in [cm]	Maximum Torque ft/lbs [Nm]
ASA9500	Adjustable Small Clamp Style Tool Holder	1.3 - 1.5 [3.3 - 3.8]	100 [136]
ASA9501	Adjustable Large Clamp Style Tool Holder	1.75 - 2.25 [4.5 - 5.7]	100 [136]

Adjustment screws allow the user to resize this clamp style tool holder to accommodate a wide variety of tool diameters. Fix mounted style tool holder. Does not rotate.

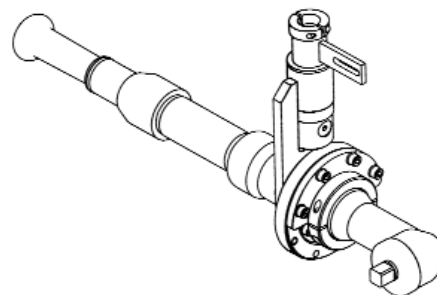

Custom designed rotate tool holders are available. Please contact your Knight representative for more information.

## Arm Accessories

A



Booms

B



Friction Brake

C



Spacer

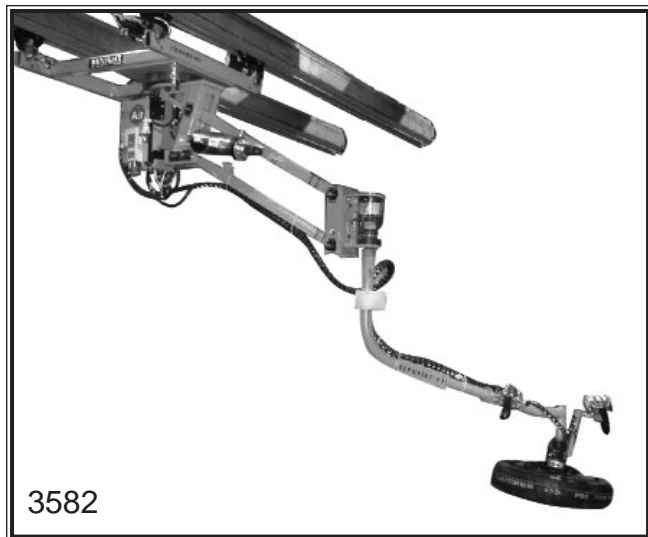

3582

Expanding mandrel fixture to load spare tire.

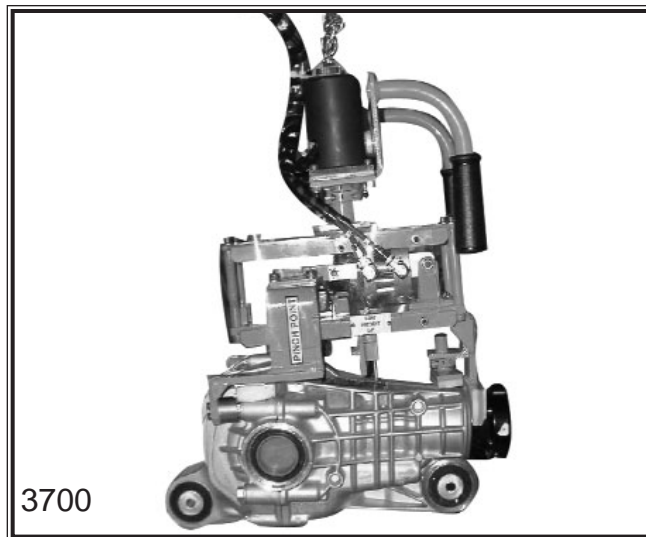

3700

Clamp style front end transfer from cart to dunnage.

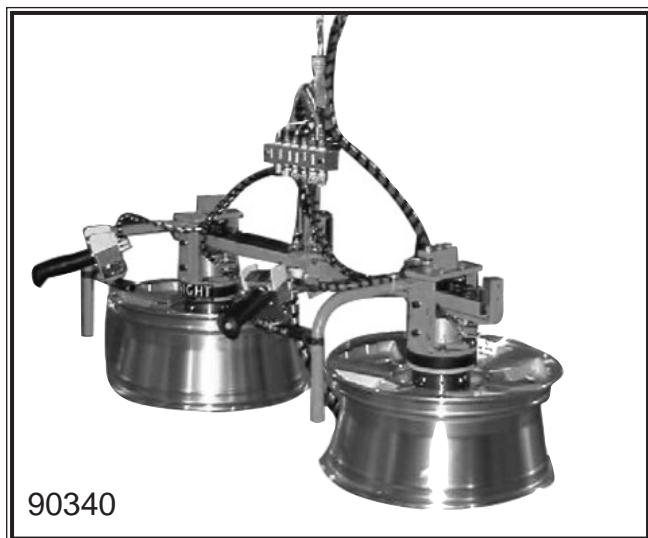

90340

Dual expanding mandrel fixture to transfer rims.

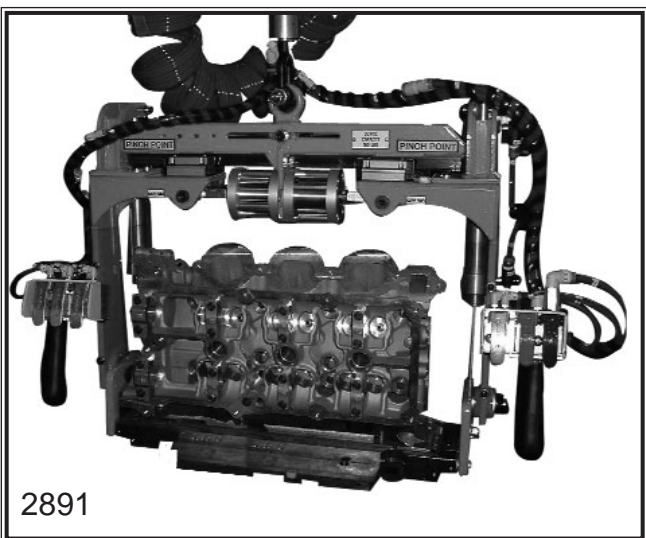

2891

Engine head power clamp and power tilt to transfer plate 90°

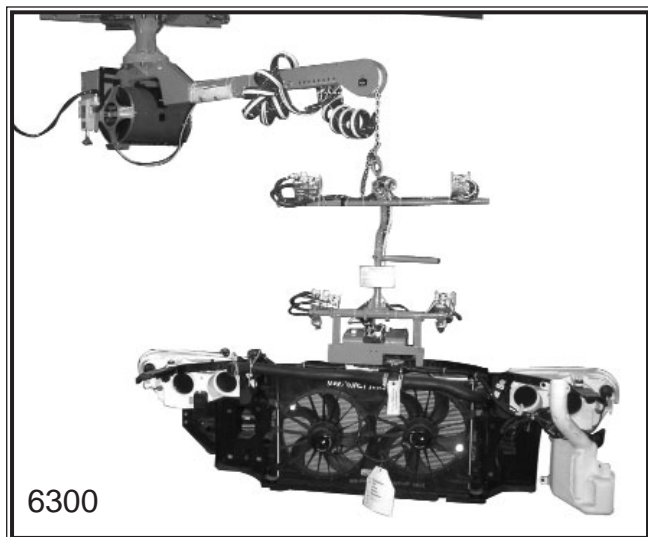

6300

Banjo Arm with clamp style fixture to load front end module.

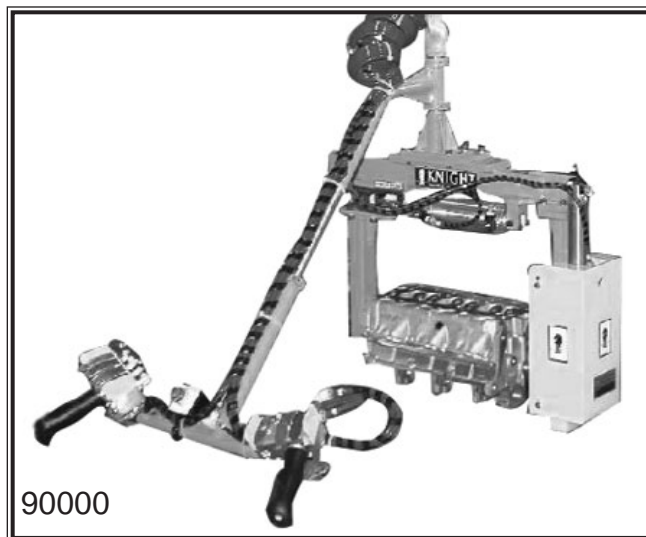

90000

Clamp style fixture to pick up and roll head.

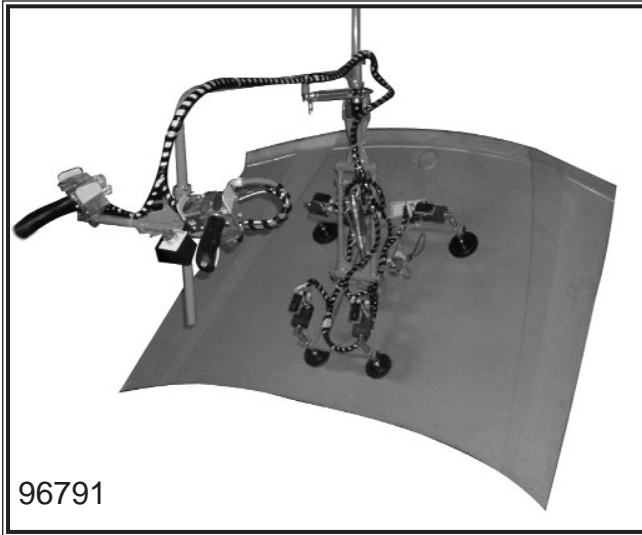

96791

Four cup vacuum fixture with 90° rotate to transfer hood



83979

Rear Seat clamping fixture to transfer seats on dunnage

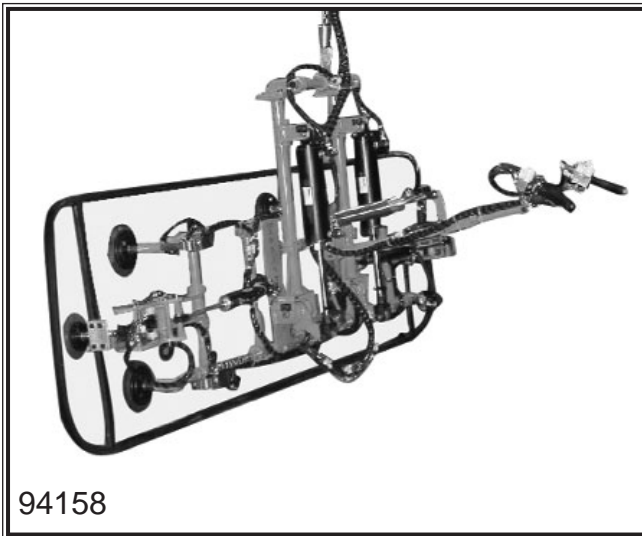

94158

Eight cup vacuum fixture to transfer windshield install



84695

Two Cup vacuum fixture with clamp to transfer tailgate

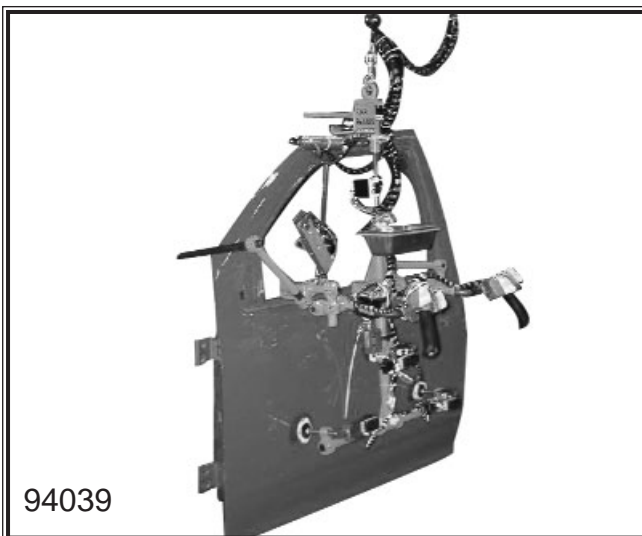

94039

Two cup vacuum fixture to transfer door to car body

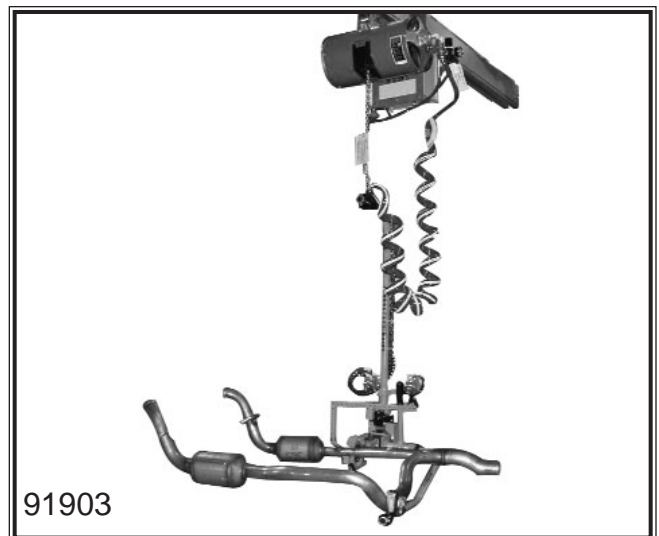

91903

Hook style fixture to install y-pipe with 90° power rotate

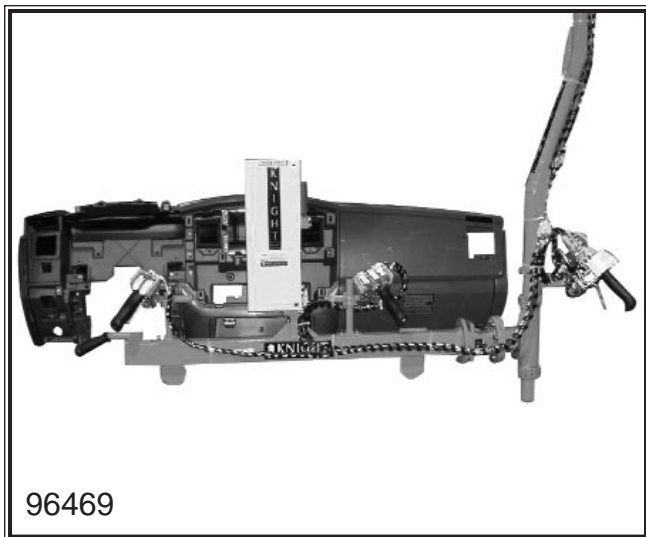

96469  
Clamp style fixture to transfer instrument panel

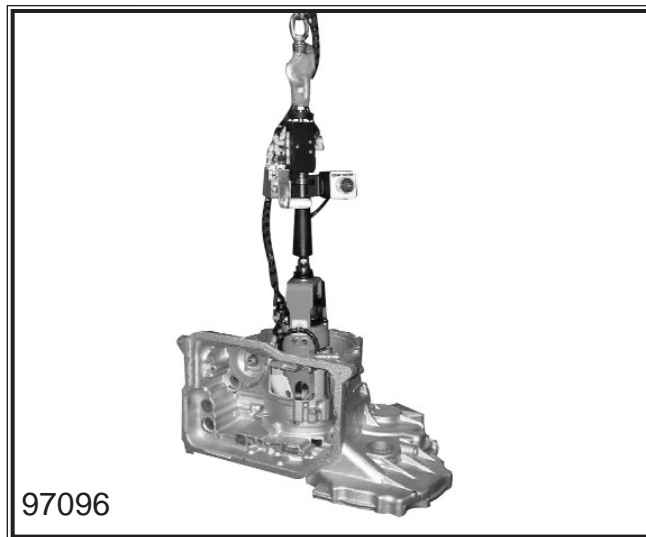

97096  
I.D. Clamp style fixture to transfer trans case

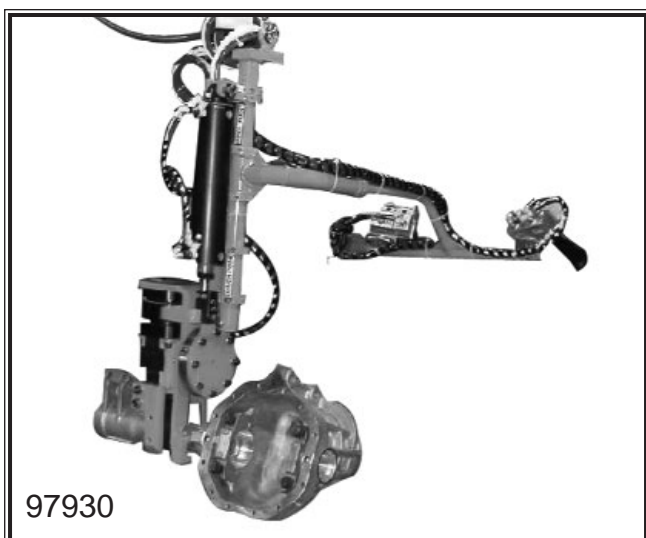

97930  
Clamp style fixture to transfer axle assembly



99337  
Articulating Arm with clamp style seat load

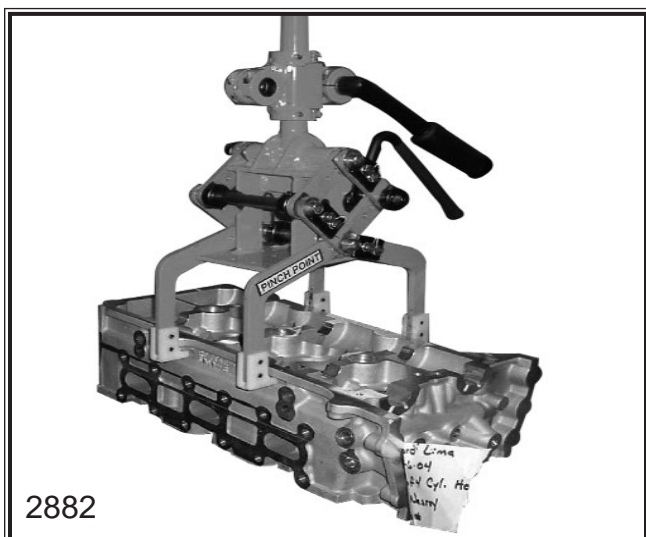

2882  
Manual clamping fixture to transfer part and empty dunnage

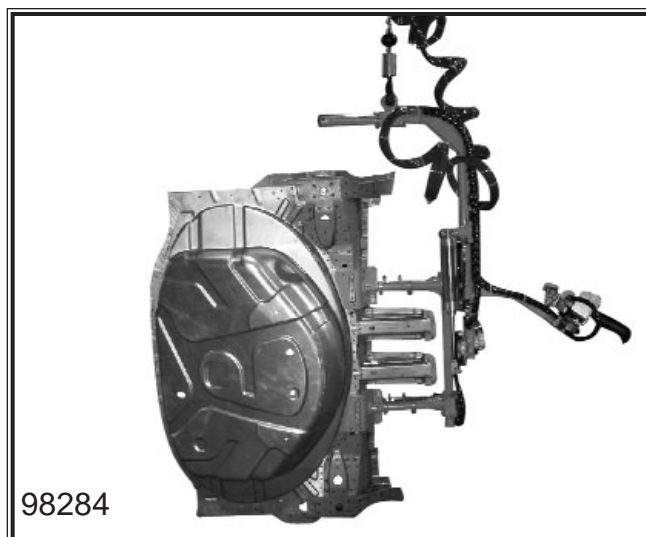

98284  
Clamp style rear pan fixture with 90° to transfer part from dunnage to vehicle



97653

Hook style fixture to lift and transfer commode



98544

I.D. clamp style fixture to transfer bin



84999

Four cup vacuum fixture to transfer box

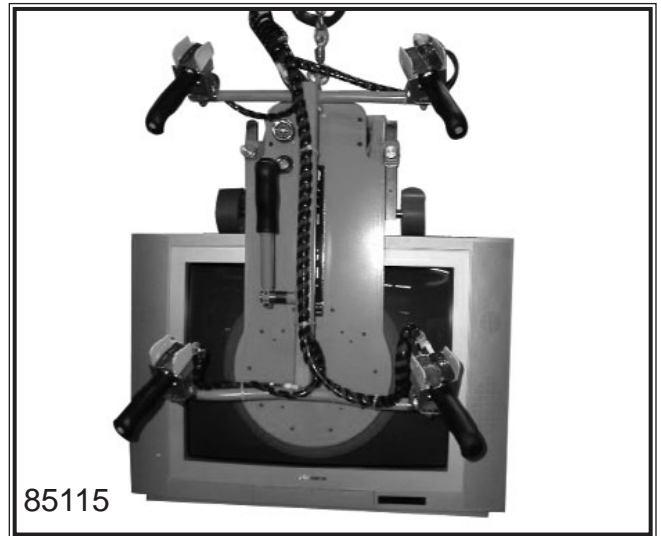

85115

One cup vacuum fixture to transfer television from conveyor to box

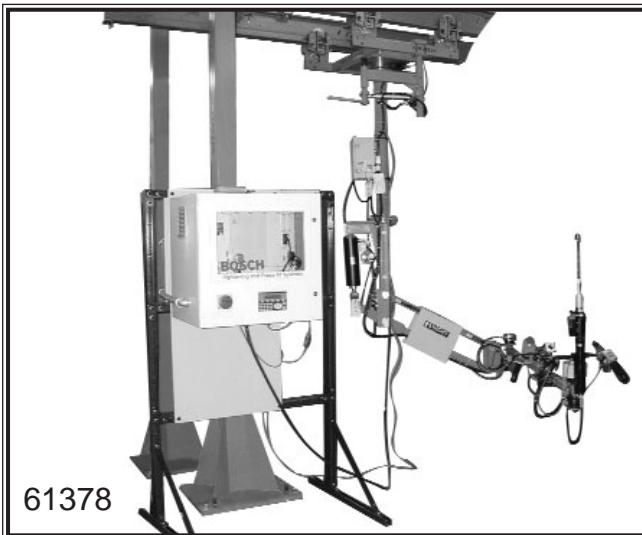

61378

Articulating arm with tracking dog and single D.C. electric nutrunner



88918

Smart cart with I.D. gripper to rotate rolls from vertical to horizontal.

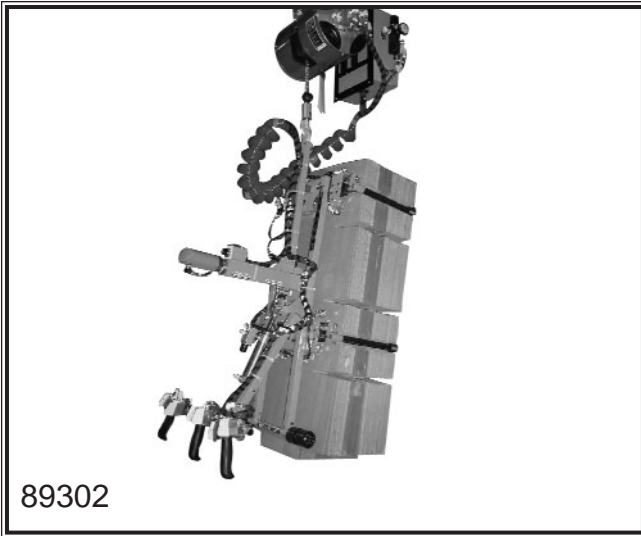

89302

Clamp style fixture to lift and rotate box stacks

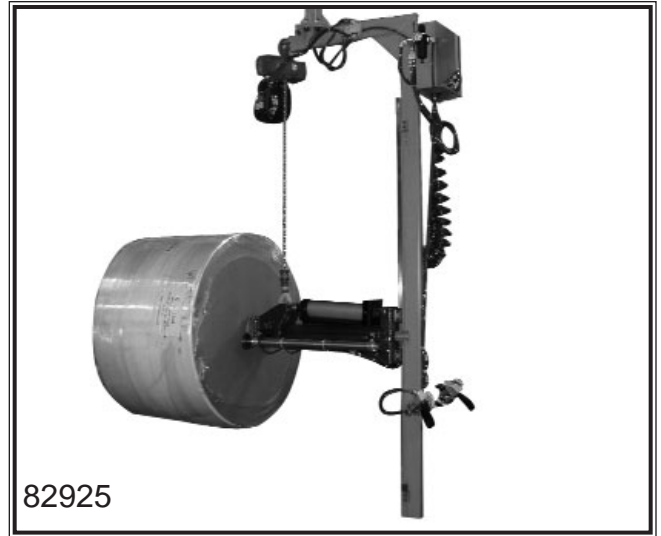

82925

Roll Handling fixture with 90° rotate and power push-off features.



89450

Ergo Seat to assist operator

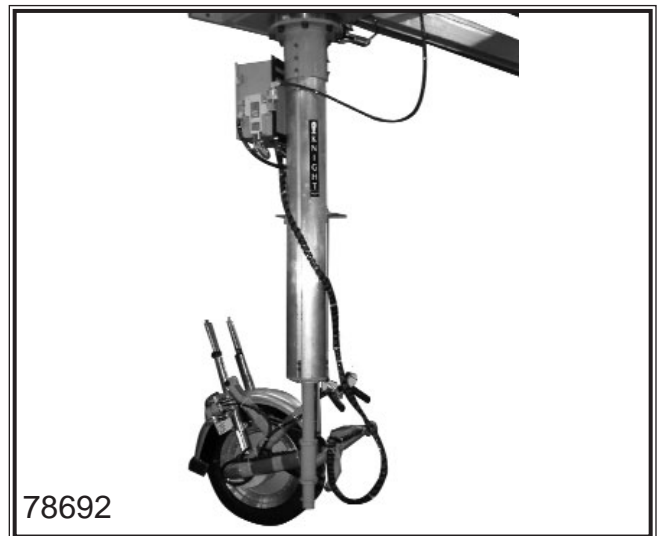

78692

Clamp style fixture to transfer motorcycle front end



77982

Clamp style clean air fixture with 180° rotate.

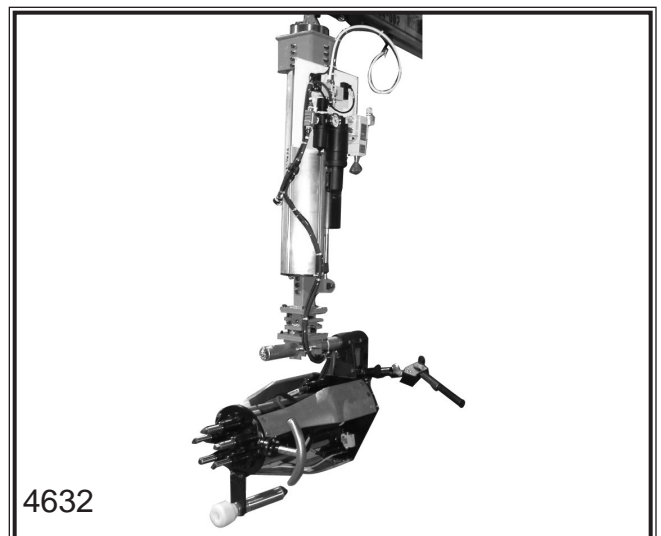

4632

Vertical balance arm with 5 spindle multiple.